

A Member of The TAPTITE 2000[®] Family of Fasteners



Leaders in Lowering the Cost of Assembly



TWIN LEAD HELIX PROVIDES STARTING STABILITY

FORWARD EXTRUSION WITH DIAMETRICALLY OPPOSED THREAD ENGAGEMENT

INCREASED CORE DIAMETER APPROACHING THE UNDERSIDE OF THE HEAD CAUSES ADDITIONAL FORWARD AND BACKWARD EXTRUSION PROVIDING INCREASED THREAD ENGAGEMENT

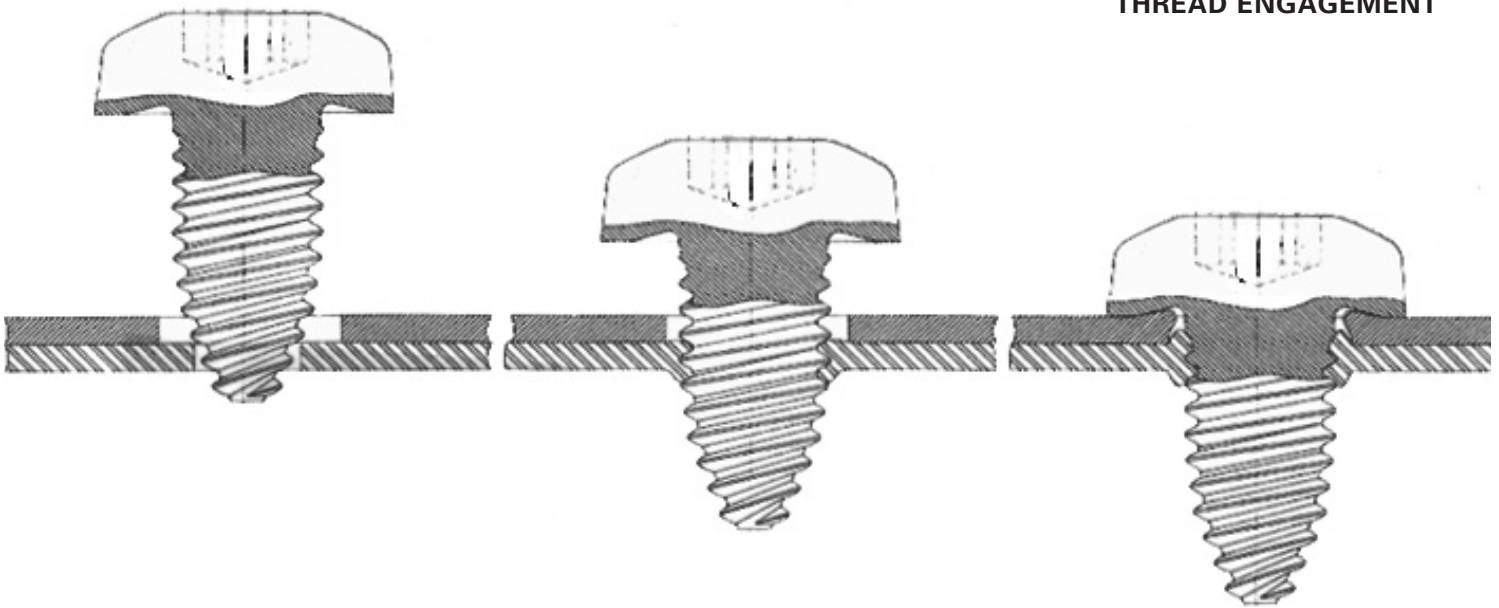

THE SOLUTION FOR THIN SHEET METAL APPLICATIONS

Over the last several years, industry has improved assembly processes and reduced the size and weight of components made from thin sheet metal and fasteners used to join these components. As a result, 0.5mm thick sheet metal is not an uncommon thickness for a typical assembly. Yet today's assembly solutions are limited and often poorly designed for both joint performance and overall cost efficiency.

FASTITE® 2000™ thread forming screws were developed to create strong mechanical joints with excellent thread engagement into untapped thin sheets, while providing the **"LOWER IN-PLACE COST SAVINGS"** associated with TRILOBULAR™ thread forming screws. FASTITE® 2000™ screws result in a cost-effective joint with increased failure torque and resistance to stripping, when compared to other fastener types and assemblies.

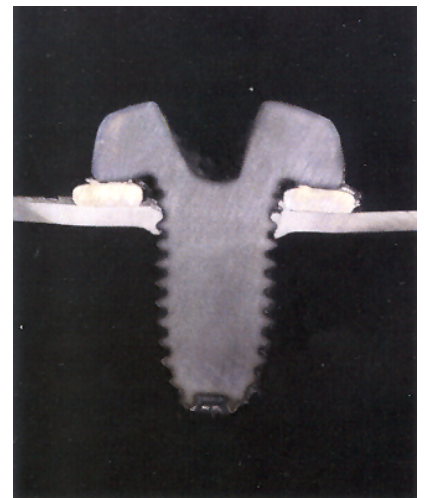

A Member of The TAPTITE 2000® Family of Fasteners



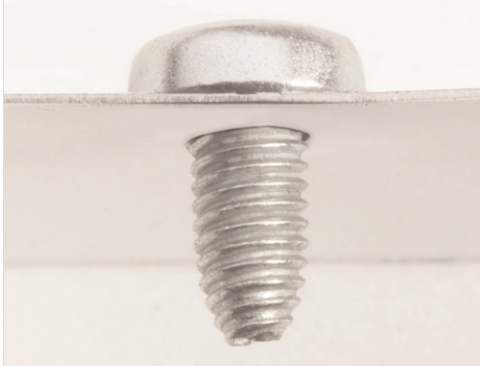

FASTITE® Fastener starts straight and finishes straight, providing a secure, tight assembly. The double lead thread centers the fastener in the hole.

Standard type AB screws lean over as the screw tends to align with the helix angle of the thread. Stripped threads or loose assemblies result.

Performance Features

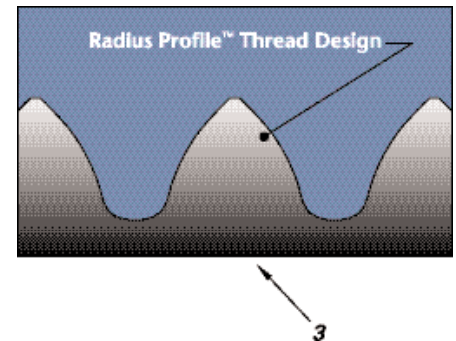
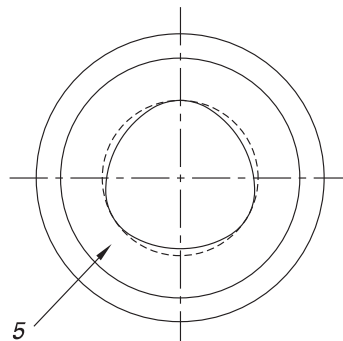
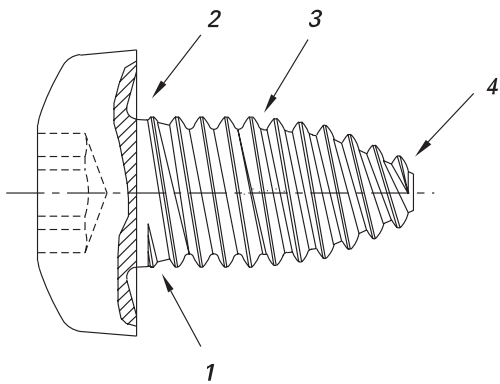

1. Tapered thread root adjacent to the screw head to maintain major thread diameter close to the head.
2. Undercut feature to increase assembly failure torque.
3. Radius Profile™ thread design combined with the twin-lead helix angle to provide a mating thread system whereby diametrically opposed threads are engaged.
4. Non cut-off "CA" style point for extruding in small holes.
5. TRILOBULAR™ screw thread body to provide "resistance to loosening".

REMINC/CONTI

Research Engineering & Manufacturing Inc. (REMINC) and Conti Fasteners AG (CONTI) have successfully marketed TAPTITE® fastener technology internationally since 1961. Their success has been accomplished by licensing and training leading fastener producers worldwide.

The technical program in the United States is under the direction of REMINC, located in Middletown, Rhode Island and in other countries under the direction of CONTI, situated in Baar, Switzerland.

Although REMINC and CONTI are separate corporations and operate independently, each is dependent on the other for certain functional activities.

AVAILABILITY

Currently there are 68 qualified producers located in 20 countries utilizing the Technical Know-How, Patents, Trademarks, and Engineering and Marketing services of REMINC/CONTI. These producers delivered a volume in excess of 17,000,000,000 pieces of Trilobular™ fasteners in 2000, comprising a mix of products.

The proprietary products available in the program are marketed and sold, not as fastener items, but rather as **COST REDUCTIONS TO END-USERS OF ASSEMBLED PRODUCTS.**

The proprietary fasteners offered to the assemblers are the means to an end, i.e. used to generate cost reductions while at the same time providing reliably tightened joints.

ORDERING/SUPPLY

When ordering from qualified Trilobular™ fastener producers, be sure in all cases to specify the FASTITE® brand name, thread size, nominal length, head style, or any other special features required, finish, and quantity.

DISCLAIMER CLAUSE

The values shown in this brochure are for guidance only. They are not meant to be used for design criteria. Their use and reliance thereon for any purpose by anyone is entirely voluntary and at the sole risk of the user. REMINC/CONTI are not responsible for any loss, claim, or damage resulting from their use. Consult our application engineers or the application engineering department of one of our many qualified producers for your specific application data.

TECHNICAL ASSISTANCE

This brochure contains basic information needed to achieve the cost-savings potential of FASTITE® fasteners.

To obtain further assistance and a list of qualified producers, visit our website at www.taptite.net or contact;

REMINC
Tel: 401-841-8880
Email: reminc@reminc.net

CONTI Fasteners AG
Tel: +41 (0)41/761 58 22
Email: conti@contifasteners.ch

SERVICES

A summary of the capabilities of REMINC/CONTI in support of manufacturers:

Technical Support

- New Product Development
- Research and Development Reports
- Technical Manuals
- Technical Reports
- Technical Information Updates
- Engineering Consultation
- Computer Aided Design and Analysis
- Engineering Training
- Tooling Design and Procurement
- Manufacturing Guidance
- Manufacturing Cost Reduction
- Metallurgical Analysis
- End-User Application Guidance
- Technical Training Seminars

MARKETING SUPPORT

- Application Definition
- Application Reports
- Performance Documentation
- Sales Seminars
- Audio/Video Materials
- Graphics
- Customer Product Brochures
- Technical Liaison
- Joint Customer Visits
- Cooperative Studies
- Trademark and Patent Use

In addition to the above stated detail, REMINC/CONTI are positioned to provide:

- Contract Testing
- Contract Engineering
- Consultation Activities
- Contract Joint Analysis
- Fastener Engineering Training

Patents and trademarks issued and/or pending worldwide.



Research Engineering & Manufacturing Inc.
25 Enterprise Center, Middletown, RI USA 02842
Tel: 401-841-8880 Fax: 401-841-5008
www.taptite.net
Email: reminc@reminc.net



CONTI Fasteners AG
Albisstrasse 15, 6340 Baar (ZG) Switzerland
Tel: +41 (0)41/761 58 22 Fax: +41 (0)41/761 30 18
www.taptite.net
Email: conti@contifasteners.ch